

## **CRYPTO MONEY BITCOIN: ITS OCCURRENCE, PROCESS AND IMPACTS**

<sup>1</sup>Bedriye KOÇ, <sup>2</sup>Nurgün KOÇ

<sup>1</sup>Karabük University, Turkey

<sup>2</sup>Associate Professor; Karabük University, Turkey

### **ABSTRACT**

The activists who are against the capitalist system have started to dream about the money which is independent from the money markets and The Central Banks and which is not connected to any authorities, and to work on it with the contributions of technology. As its tryouts have been made many times, none of them could not caught Bitcoin's success, and they have been excluded from the market. The most important reason of Bitcoin's success is its timing. It abused the trust on the banking system that Lehman Brothers which was the biggest fourth investment bank in United States of America declared its bankrupt in the economic crisis which was in the country in 2008, and the new seekings were started. Meanwhile "Bitcoin" which can be transacted without requiring the banking system and having the high expenses which are paid to the banks was declared.

**Keywords:** Bitcoin, Crypto currency, Bitcoin miner, Block chain, Bitcoin wallet.

### **1. INTRODUCTION**

#### **1.1 Bitcoin's Occurrence**

The commerce of goods have gone on from the beginning of history of humanity to today. The various interchange tools have been used as the payment method in accordance with their conditions in each period. Even if it has diminished today, it has stil sustained as a payment method in the various commerce fields. The technological developments have become a solution for the reluctance of handling the money in the last centenarian period, and the credit cards have been a new trend. The plastic cards have been an important part in our life in the current situation (Bilir- Çay, 2016, 22).

The most important fact of our world in the recent period is the globalization. (Balay, 2004, 62). The rapid development of information and communication technology and the increasing

integration of economies in the globalizing world have raised and diversified today's consumers' demands. An order can be given from the far end of the world to its other end with the help of a wide knowledge network, and this situation can be made in very rapid and pragmatic way. (Zengin- Güngördü, 2013, 130) This new dealing trend has been possible with the development of money-loaded electronic cards and the bitcoin.

There are some disadvantages of electronic money while it has got some facilities. The electronic money's power to create the bank money in the form of "money-loaded cards" and "bitcoins" and to make their own system cause some discussions in terms of the financial markets' stability. The situations of governments and the central banks against the electronic money and currencies have started to be interrogated with this new paradigm, it has started to be interrogated how the central banks which try to direct the economy through the reserve money adapt the new position, and which instruments they will use against the changing conditions (Bilir- Çay, 2016, 22)

It has not still been clear whether the Bitcoin that its name is mostly heard in the bitcoins is a cryptocurrency, digital money or a ponzi scheme. As many things are known about it, nothing is known. Many explanation has been made about Bitcoin, the articles have been written, even the songs have been written and it has become very interesting manner today.

"Bitcoin was declared by Satoshi Nakamoto, who is Japanese, in 2008 and the generation of Bitcoin was firstly made in 2009. Hundreds of members who are the cryptography expert and fanciers got an e-mail which was in the uncertain e-mail list from a person who said Satoshi Nakamoto for himself in Newyork at 14.10 on 31 October in 2008". (Vigna-Casey, 2017, 66)

The explanation on Bitcoin attracted attention too much. Even if those operations which will be made on the virtual platform without being connected to any centers didn't sound believable firstly for many people, they started to be common with the followers such as Finney. "They started to work together on the subject which will be a two-week dense dual program on 10 January, 2009. While they were in an effort to complete the bitcoin protocol and to operate it, they were to collaborate via e-mail and they were to share with the notes. Finney downloaded the software as following the instructions of bitcoin founder, he created a wallet and started to give 50-bitcoin block. This operation made him Number Two Joint. Nakamoto sent 10 bitcoins to his new friend's wallet as a test. Finney became the first person who bought the bitcoin from another one" (Vigna-Casey, 2017, 75).

According to the common view of all the crypto experts, those studies dated back. Moreover, many tryouts had been made but they could not be succeeded. Actually, the tryouts for the cryptocurrency or bitcoin can be seen in the manifest that the members of Cypherpunk, which is a famous activist community, published in 1993. However, Satoshi Nakamoto's explanation

following The Real Estate Crisis and the giant ones' bankrupt such as Lehman Brothers became one of the most important reasons for Bitcoin's success.

Firstly, it could not be known exactly whether the name of Satoshi Nakamoto belongs to a real person or it was determined as a nickname. As a result of the searches which were made in those periods, the real identity could not be found and it was determined that IP address was in Japan. A few persons who can have such a complex cryptography knowledge are seen.

The world's prominent broadcasting organizations such as The New Yorker and Newsweek prepared a special file in order to reveal Satoshi Nakamoto's identity who is the mysterious creator of Bitcoin. Wright's name is seen among the possible creators of Bitcoin on the news. The bitcoin's creator who could't endure to such insistent searches and oppressions declared his real identity in 2016. "Craig Wright who is an Austrian entrepreneur put an end to the discussions which have gone on for years and he declared that he is actually Satoshi Nakamoto who is the inventor of Bitcoin. Wright who declared his identity proved that he is the bitcoin's creator as he shared the technical data which was known to belong to Bitcoin's creator. Wright who declared his identity only to BBC and The Journals of Economist and GQ said that he doesn't want to be Bitcoin's face and he said *'I declared my identity because there were the increasing control on me in the last time. I would not have declared my identity if I had to do it. I don't want to have a reputation nor money. It is enough that you let me alone'*". (<https://tr.sputniknews.com/ekonomi/201605021022488232-bitcoin-avustral-ya-craig-wright>)

## **2. THE MAIN TERMS RELATED TO THE BITCOIN**

### **2.1 The Bitcoin Miner**

The Bitcoin's producers are named as "The Bitcoin Miner". The mining is the general name of the process to obtain Bitcoin which is produced at the end of operation to make the mathematical operations with the use of calculation capacity and operation power." The term of "Miner" is used for the person in Bitcoin network that he/she makes the operations which require the dense processor power on the hardwares as Bitcoin's software which is presented to make these operations is downloaded. (Gültekin, 2017, 101)

Bitcoins which are previously promised on condition that they solve the quite complex problems which are presented by the bitcoin mine software are given as an award. While its miners gained 50 bitcoins at the beginning, it was reduced to 25 Bitcoins laterly. The advantage will be gotten in the operations' expenses, that Bitcoin will not be gained, in the further days. The bitcoin upper limit which can be produced has been determined as 21 millions by Satoshi Nakamoto.

A special computer hardware is required in order to start the bitcoin mining today. As it was possible to solve such an operation with the houselike computer at the beginning, it has not been possible due to the increase in the access of system anylonger. Moreover, as it takes very long time and is very expensive to meet the energy need which will increase on each question again, it will be easier to be in the system as getting bitcoins from Bitcoin Stock Exchange.

When the bitcoin technology is reviewed, it is necessary that quite difficult algorithms are solved. As it is such a complex and difficult one, it can not be solved by everyone, it is compulsory that the operation is made in The Bitcoin Stock Exchange.

“The amount of bitcoin to be produced is calculated as some of the mathematical problems which have a certain difficulty level are solved by an algorithm which comprises the brain of Bitcoin software. As the process is very complex, the computer power which is required for the calculations is too much. It is not possible to meet this need with some normal computers. As Bitcoin is open source code-based act and it is impossible that this base has got the high-capacity super computers at least now, the necessary operation power for the calculations are jointly created by the high-capacity computers which are connected to a computer network (exactly a Peer-to-Peer-Network, briefly P2P). An award of 25 Bitcoins as an average is given to each of Bitcoin Miner, who give their computers to this network to solve each of mathematical problem at a certain difficulty level, by the bitcoin software.” (Ateş, 2016, 357).

## **2.2 The Bitcoin Chain**

Number one of the block chain occurred as Satoshi Nakamoto got the address of “bitcoin.org”, saved the necessary program interface on the desktop computer in order to take out the first bitcoin. Finney was the first person who replied Satoshi Nakamoto’s mail that he included in the block chain. Finney downloaded Satoshi Nakamoto’s instructions and started to take out Bitcoin. He was the second person who included in the block chain.

Peer to peer technology is used in the block chain. P2p technology’s first application is Napster MP3 download program. It finds the MP3 tracks which are recorded on all the computers and shares with the millions of computers. The implementation is made similarly for the bitcoin processing. All the operations are spreaded over all the network. They are approved by other users of network and they are added to the block chain. All the operations from the first operation to today’s operations have been recorded on the system. However, the information of people who make the operation is hidden ([http://www.elektrikport.com/teknik-kutuphane/peer-to-peer-\(p2p\)-aglar-nedir-ve-nasil-calisir/15406#ad-image-1](http://www.elektrikport.com/teknik-kutuphane/peer-to-peer-(p2p)-aglar-nedir-ve-nasil-calisir/15406#ad-image-1))

The flowchart of Bitcoins which are used as they are bought from the bitcoin miner or Bitcoin Stock Exchange is seen at the following tables.

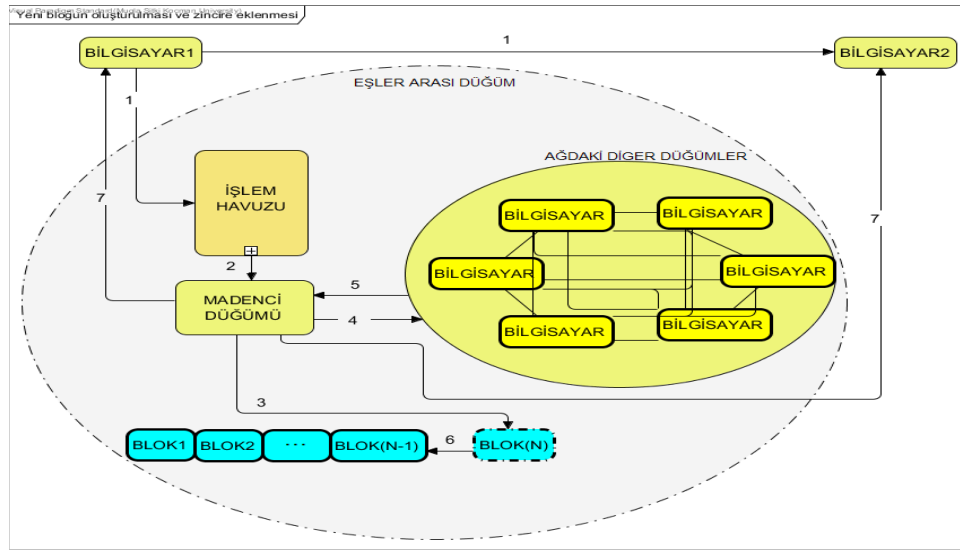

**Figure 1: The Junction Process of New Block on The Block-Chain-Based Application (Karaaslan- Akbaş)**

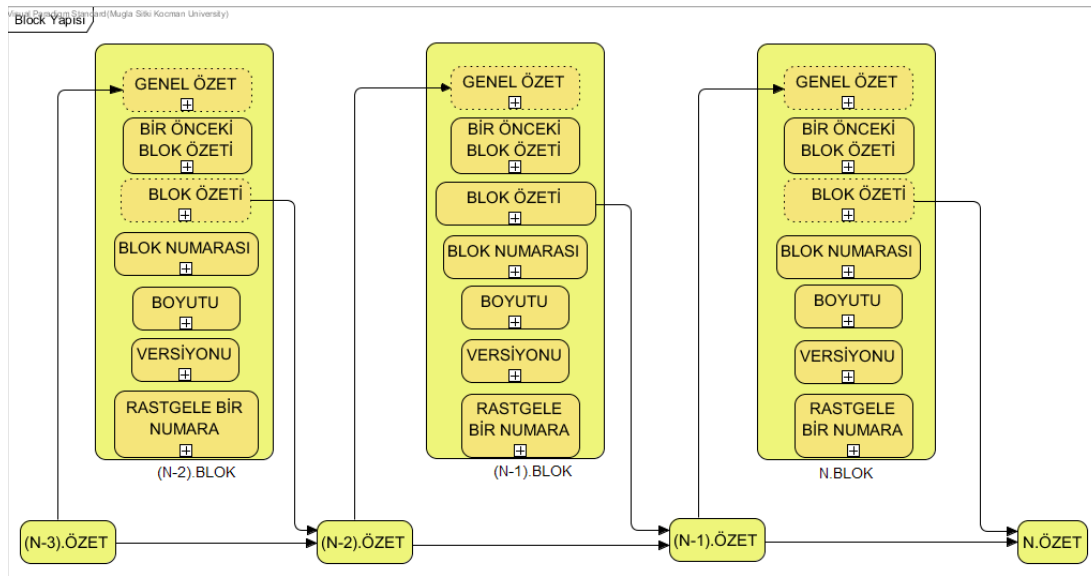

**Figure 2: The Structure of Block Chain (Karaarslan- Akbaş)**

1. "Computer 1 publishes the operation to be made on the peer-to-peer network including Computer 2,
2. The usage of mining pool can be optional on the system, the operations are learned with the publishing. The operations which are not verified are called by the joints,

3. According to the protocol which is used on the network, the operation in number n can be written collectively on the block. The joints make a new block,
4. The publishing is made onto the computers on the peer-to-peer network for the confirmation,
5. The information about that the confirmation information is completed is sent on the network, a miner joint is chosen with the consensus protocol on the peer-to-peer network.
6. The miner joint which is chosen is added to the new block's chain,
7. The information about that the operation in demand is completed is sent to the machinery that the operation is made.

The blocks connect to the previous blocks with the hash value. The general hash value is created through the hash value on the previous blocks in this process. At the same time, the hash of previous block is recorded. In the block; the base hash (Merkle tree) creation from the hashes in the case that 4 operations are summed and written on a block has been given on Figure 3.” (Karaarslan- Akbaş)

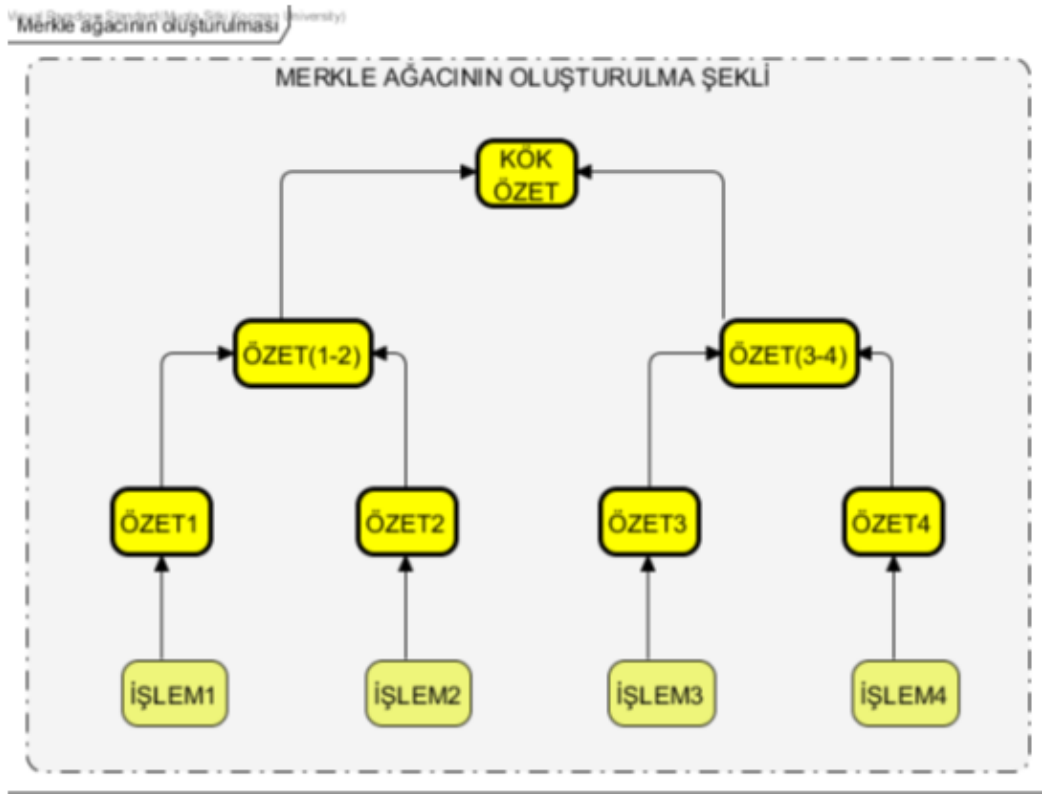

Figure 3: The Building of Merkle Tree (Karaarslan- Akbaş)

When the system is considered, the operation volume is accepted as a practical one in the case that it is not very high, it will take long time to record such information and to verify the operation in the case that the operation volume increases. It is clear that the high expenses will occur in order to reduce this duration. So the advantage of having less operation cost will disappear according to the banks as one of the occurrence goals. Moreover, the speed advantage in the payments which are made via the credit cards will not be gotten, the durations which get longer in the payments that are made via Bitcoin will create a problem.

### **2.3 The Bitcoin Stock Exchange**

Bitcoins were obtained with the method of Bitcoin mining at the beginning. Then, it has become easier and cheaper as the operations to get the bitcoins through Bitcoin Stock Exchanges because it takes long time and the electric cost and the computers with the high equipment are very expensive.

#### **2.3.1 The Bitcoin Stock Exchanges Which Transact over The World:**

The prominent Stock Exchanges with the most operation volume and as the most reliable ones over the world have been shown as the following. ( <https://uzmancoin.com/en-iyi-bitcoin-borsalari/>)

##### **1. Binance**

The popularity of Binance that its center is in China has increased in the recent days so that it has taken its place among the highest-volume stock exchanges of world as getting the volume which exceeds 1 billion in a day. The commission rates in Binance is very low.

##### **2. KuCoin**

KuCoin, which has Chinese source, is a stock exchange in the claim of decentralization. Michael Gan who worked as a customer engineer previously in Alibaba Group is at the head of stock exchange. The stock exchange has got its own coin with the name of KuCoin Shares which has not got a center also. 90 % of the commission income is distributed to the ordinary users who have KuCoin Shares in their balance and the commission is taken from all the members' operation that they are invited. So the profit is gained as having the commerce of cryptocurrency and the stock exchange gives an important sharing from its income.

##### **3. Coinbase**

It is among the most well-known and reliable stock exchanges over the world. The operation is made with Ethereum and Litecoin except from Bitcoin also.



#### **4. Kraken**

Kraken assures the investment with Euro capacity and because it states its authorities' identity clearly. The operations such as Ethereum, Litecoin and Ripple except from Bitcoin are made in Kraken. Moreover, it provides a well customer relation and has made the cheap operations.

#### **5. Cex.io**

Cex.io gives an opportunity to make the operations with Bitcoin and many other digital currencies as it is in the other stock exchanges. Cex.io's attention-grabbing aspect is that it can be bought via a credit card. Its another attention-grabbing aspect is that it gives an opportunity to the use of practical face plate for the new starters.

#### **6. Shapeshift**

Shapeshift it can make its operations through the digital money such as Bitcoin, Ethereum, Moner, Zcash, Dash, Dogecoin. It is allowed to make the operations through the credit cards and bank cards with Shapeshift as it is in Cex.io's stock exchange. Its attention-grabbing aspect is that it allows that an operation is made without requiring the member registration. Moreover, its operation price is very cheap and the operation speed is high.

#### **7. Poloniex**

Poloniex comes into prominent as a stock exchange with the highest operation volume. Poloniex gives the opportunity to trade of digital money.

### **2.3.2 The Bitcoin Stock Exchanges Which Transact in Turkey:**

While it was not possible to buy and sell Bitcoin with Turkish Lira in Turkey a few years ago, many platforms service for its users for the commerce of Bitcoin and cryptocurrency today. The prominent cryptocurrency stock exchanges have been shown as the following. (<https://kriptoparahaber.com/turkiyedeki-bitcoin-ve-kripto-para-borsalari.html>)

#### **1. Btcturk**

It is the first Turkish stock exchange that the operation was firstly made via Bitcoin. It is necessary to make the member registration in order to make an operation. Btcturk which has its origin from Northern Cyprus discontinued to make its operations as it had some problems with the banks in the past. However, it started to make the operations again as having its center in Turkey on May, 2017. The operation is made through Bitcoin and Ethereum. When it is



considered in terms of the customer dissatisfaction, it is seen that it is insufficient with long durations to verify the accountings and with the customer satisfaction.

## **2. Koineks**

It is seen that it gives an opportunity to make the operation with Bitcoin, Ethereum, Litecoin, Dash and Dogecoin. Although it has been newly established, it is interesting that it has its operations through 5 digital currencies and works with 12 banks. Another strategy which will provide Koineks to come into the prominence is that its confirmation duration is very short and its customer satisfaction is very fast.

## **3. Koinim**

It comes into the prominent because it gives an opportunity to barter Bitcoin and Litecoin. It requires the confirmation of identity for the high operation volumes. Moreover, the operation of withdrawing is made in 5 working days. It is seen that the customer complaints are mostly related to the delays in the refunds.

## **4. Paribu**

Paribu was opened in 2017. It has got a practical interface for the new users. It is seen that it doesn't require the identity confirmation for the operations which are less than the certain limits. It attracts attention with its success on the customer relations in the comments.

## **5. Bitturk**

Bitturk which has been for one or two weeks is the first platform which provides the commerce of Ripple XRP with Turkish Lira. The firm has not taken any commission charge yet.

Many positive and negative comments related to Bitcoin stock exchange are made and it is seen that it is more efficient to make the operations on the stock exchange because the investors who will make high operations and Bitcoin mining have the increasing costs.

### **2.4 The Bitcoin Wallet**

Where and how should Bitcoins which are taken out as the bitcoin miner or Bitcoins of a reliable bitcoin stock exchange be kept? It is necessary to consider the various criteria in order to answer this question. When we think about the recent news about a great deal of bitcoin robbery the importance of this selection has increased. The types of bitcoin wallets have been mentioned as the following.

#### **2.4.1 The Hot Wallets:**

#### **2.4.1.1 The Desktop Wallets**

“The Desktop wallets have their own webpages and the wallet software is downloaded through these sites. After the download of software, its installation on the computer is made and then, the control of wallet belongs to you. After the installation is completed, the wallet gives a private key for you and you guarantee your wallet with this key.” (<http://www.meko9.com/kripto-para-cuzdan-cesitleri-ve-ozellikleri/>)

The desktop wallets are one of the most reliable wallet types on condition that there is not an internet connection. The disadvantage to be seen on the desktop wallets is that all the block chain is loaded on the computer. The whole block chain which is loaded takes a great place on the computer and the download duration takes too much time.

#### **2.4.1.2 The Web Wallets**

There are web-based wallets belonging to the sites which have the commerce of the bitcoin. As it is more accessible than the desktop wallets, it has the advantage. The most important problem which can be seen is that there is high possibility to be hacked. In order to have this problem, there are a few secure confirmation steps. They are sms, e-mail, multi-signature. (<http://www.meko9.com/kripto-para-cuzdan-cesitleri-ve-ozellikleri/>)

#### **2.4.1.3 The Mobile Wallets**

The mobile wallets are definitely the most practical and useful wallets today that the mobile phones have such a dense usage field.

“The mobile wallets are the cryptocurrency wallets that we install them on the smart phones as we understand from its name. These wallets are similar to the web wallets. They don't load the block chains on your phone as API wallets make them. They have got all of the security features that the web wallets have got them and the most useful one among them is the confirmation of QR code. Some of web wallets have their own mobile wallets.” (<http://www.meko9.com/kripto-para-cuzdan-cesitleri-ve-ozellikleri/>)

### **2.4.2 The Cold Wallet:**

#### **2.4.2.1 The Paper Wallets**

It is accepted as the most reliable wallet type. However, the field that they will have and the reliable place to be kept can be a problem. However, it is definite that there is not possibility to be hacked.

#### **2.4.2.2 The Brain Wallets**

The password that the person creates it is used as a principle. So it is important that you should not forget the passwords. If you forget the password, it will be impossible to access your bitcoins.

#### **2.4.2.3 The Equipment Wallet**

The equipment wallets are known as the most reliable wallets after the paper wallets. They are USBs which are produced to keep the cryptocurrency as the principle.

### **3. THE BITCOIN'S USAGE IN DAILY LIFE AND ITS RELIABILITY**

Although the daily usage of Bitcoin has increased, it is seen that it has not been sufficient yet. The first dealing which was made by Bitcoin is the pizza which was ordered by Hanvecz on 18 May. He wrote down the following manners on Bitcoin Forum which has got a few members: "I will pay 10.000 bitcoins for two big pizzas so one or two slices will have been for the next day." (Vigna-Casey, 2017, 117) Although there were not any firms who accepted Bitcoin for the commerce in the period, many companies have started to accept Bitcoin today. It is seen that there are a few companies which accept Bitcoin in Turkey.

The Firms Which Accept Bitcoin in Turkey:

<b>Field</b>	<b>Company</b>	<b>Web</b>
3D Printer	3Dörtgen	<a href="http://3dortgen.com">3dortgen.com</a>
Informatics	5Mbilisim	<a href="http://www.5mbilisim.com/">www.5mbilisim.com/</a>
Informatics	Adres Bilgisayar	<a href="http://adresbilgisayar.com">adresbilgisayar.com</a>
Informatics	Bilgisayar Teknik Servis Hizmetleri	<a href="http://bilisimciniz.com">bilisimciniz.com</a>
Informatics	Gifted Coder	<a href="https://facebook.com/giftedcoder">facebook.com/giftedcoder</a>
Informatics	Internetq	<a href="http://internetq.com">internetq.com</a>

Informatics	Kayrasoft	<a href="http://Kayrasoft.com.tr">Kayrasoft.com.tr</a>
Informatics	ONOFİS İnternet Hizmetleri	<a href="https://www.onofis.com/">https://www.onofis.com/</a>
Informatics	Saydam Bilişim	<a href="http://saydambilisim.net">saydambilisim.net</a>
Informatics	Siyaz Beyaz Bilişim	<a href="http://Siyahbeyaz.com">Siyahbeyaz.com</a>
Informatics	Vopsinyalleri	<a href="http://viopsinyalleri.com">viopsinyalleri.com</a>
Informatics	Motto Yazılım Tasarım	<a href="http://www.mottods.com/">http://www.mottods.com/</a>
Translation	Translation Genie	<a href="http://translationgenie.com">translationgenie.com</a>
Consultancy	1e1consulting	<a href="http://1e1consulting.com">1e1consulting.com</a>
Domain	Alan Adları	<a href="http://alanadlari.com">alanadlari.com</a>
Pharmacy	İstasyon Eczanesi	<a href="https://facebook.com/istasyon">facebook.com/istasyon</a>
Entertainment	Exit Kaçış Oyunları	<a href="http://bursaexit.com">bursaexit.com</a>
Entertainment	Kaçış Merkezi	<a href="http://kacismerkezi.com">kacismerkezi.com</a>
Electronic	Seda Elektronik	<a href="http://sedaelektronik.com">sedaelektronik.com</a>
Real Estate	Protempo Gayrimenkul	<a href="https://facebook.com/protempogayrimenkul">facebook.com/protempogayrimenkul</a>
E-commerce	Binbirçeşit	<a href="http://binbircesit.com">binbircesit.com</a>
E-commerce	CoinTürk Store	<a href="http://store.coin-turk.com">store.coin-turk.com</a>

E-commerce	Halal Dünya Marketleri	<a href="http://izmithdm.com">izmithdm.com</a>
E-commerce	PlatinMarket	<a href="http://platinmarket.com">platinmarket.com</a>
Home Decoration	Armoni Perde	<a href="http://armoniperde.com.tr">armoniperde.com.tr</a>
Home Decoration	By Muhammer Ulutaş Perde	<a href="https://facebook.com/bymuhammerulutasperde">facebook.com/bymuhammerulutasperde</a>
Home Decoration	Doğan Perde	<a href="http://doganperde.com">doganperde.com</a>
Home Decoration	Nihal Perde	<a href="http://nihalperde.com">nihalperde.com</a>
Food	Lezzet İkizleri	<a href="http://Lezzetikizleri.com">Lezzetikizleri.com</a>
Hardware	Ata Fırça	<a href="http://atafirca.com">atafirca.com</a>
Law	ADVU Hukuk	<a href="http://www.advuhukuk.com/">www.advuhukuk.com/</a>
Law	Baran Hukuk	<a href="http://Baranhukuk.com">Baranhukuk.com</a>
Construction	AK İnşaat	<a href="https://facebook.com/akinsaat">facebook.com/akinsaat</a>
Construction	Demir Yapı İnşaat	<a href="http://demiryapinsaat.com">demiryapinsaat.com</a>
Construction	Sandviç Panel	<a href="http://sandvicpanel.co">sandvicpanel.co</a>
Construction	Lena Doğaltaş	<a href="http://lenadogaltas.com">lenadogaltas.com</a>

Stationer	Defter Sepeti Kırtasiye	<a href="http://deftersepeti.com">deftersepeti.com</a>
Stationer	Elt Kitap Kırtasiye	Antalya – Mağaza
Stationer	Hasret Kırtasiye	<a href="https://facebook.com/hasretkitabevi">facebook.com/hasretkitabevi</a>
Stationer	Kartusmarkt	<a href="http://Kartusmarkt.com">Kartusmarkt.com</a>
Accomodation	Kamara	<a href="http://kamara.com.tr">kamara.com.tr</a>
Accomodation	Karaburun Apart Houses	<a href="http://adormo.com">adormo.com</a>
Mechatronics	Ivmech Mechatronics	<a href="http://ivmech.com">ivmech.com</a>
Architecture	Büron Mimarlık	<a href="http://www.buronmimarlik.com.tr">www.buronmimarlik.com.tr</a>
Music	Zihni Müzik	<a href="http://zihni.com">zihni.com</a>
Optics	Ege Optik	<a href="https://facebook.com/ege">facebook.com/ege</a>
Optics	Öz Kevser Optik	<a href="http://Ozkevseroptik">Ozkevseroptik</a>
Game	Klasgame	<a href="http://Klasgame.com">Klasgame.com</a>
Game	Online Oyun Alemi	<a href="http://onlineoyunalemi.com">onlineoyunalemi.com</a>
Advertisement	Gümüşel Reklam	<a href="http://www.gumuselreklam.com/">http://www.gumuselreklam.com/</a>
Advertisement	Reset OTB Reklam Ajansı	<a href="http://kivancilisulu.com">kivancilisulu.com</a>
Advertisemen	Verim Reklam Dijital Baskı Merkezi	<a href="http://verimreklam.com">verimreklam.com</a>

Advertisemen	Virtual Digital Media	<a href="http://virtualdigitalmedia.com">virtualdigitalmedia.com</a>
Restaurant	Batman – Van Kahvaltı	<a href="https://facebook.com/van">facebook/van</a>
Restaurant	Pirinç Nişantaşı	<a href="https://facebook.com/pirinç">facebook.com/pirinç</a>
Restaurant	Rafine Gastro	<a href="https://facebook.com/rafinegastro">facebook.com/rafinegastro</a>
Health	Dr. Ali ÖZGÜR	<a href="http://homeopatinedir.com">homeopatinedir.com</a>
Health	Sanat Galeri	<a href="http://sanatgallery.com">sanatgallery.com</a>
Design	Merkur Design Digital Web Solutions	<a href="http://merkurdesign.com">merkurdesign.com</a>
Technology	Wagner Teknoloji	<a href="http://wagnerteknoloji.com">wagnerteknoloji.com</a>
Flight	Avalonjet	<a href="http://avalonjet.com">avalonjet.com</a>
Publishing	Ekovizyon Dergisi	<a href="http://ekovizyon.com.tr">ekovizyon.com.tr</a>
Publishing	İnci Kitap	<a href="http://incikitap.com">incikitap.com</a>
Publishing	Propaganda Yayınları	<a href="http://propagandayayinlari.net">propagandayayinlari.net</a>

<http://coin-turk.com>

As it is understood from the list, for example, there is not a chance to buy the gas for the car that its gas ends or to buy a ticket for the public transportation by Bitcoin while going to work as the daily life is sustained. When you want to eat something, you have to eat at the same place. It is not possible to have dealing in a market now.



However, Bitcoin ATMs that they were introduced on May in 2013 will provide to make the commerce of Bitcoin and they will be beneficial in order that Bitcoin's familiarity is provided. 16 ATMs in the different parts of USA, 16 of them in EU, 9 of them in The Far East, 5 of them Australia have been serviced for the users of Bitcoin. There is one Bitcoin ATM in Atatürk Airport. (<http://coin-turk.com/bitcoin-atmleri-hizla-yayginlasiyor>)

It is necessary to thing the reliability of Bitcoin in two ways that its daily usage has gone on in an increasing way. How much is Bitcoin reliable as a system? Another one is how Bitcoin's future will be?

Although there is always a risk as the system, it is seen that it is significantly reliable.

“The hash functions in the structure of block chain are actively used. Each of blocks have the hash of former one. The different algorithms are used as the hash function and BTC SHA256 algorithm is used. The changing of an operation in the system will provide to calculate all the blocks in the chain so that this will require a great operation power. It will require to convince the other joints for the blocks that they will change in the chain and to make PoW calculations. This is described as the attack of 51%, because it is necessary that all the joints on the network have at least 51% of the mining operator power. Even if the attack is possible in the theory, it is impossible that there is such an attack in practice and it is stated that its impact will take very short time.” (Karaarslan- Akbaş)

There are many explanations about the field related to Bitcoin's future. Those who manage the money today will loudly mention definitely about the claims that Bitcoin is a balloon. Furthermore, Bitcoin's fans protect Bitcoin as its fanatics and they even compose the songs for it. Actually, what do FED and other Central Banks think to do against this romantic approach? What are their plans for Bitcoin? Who will seal Bitcoin's fate? These questions are the main questions for Bitcoin.

#### **4. THE MONEY MARKETS AND COUNTRIES' CENTRAL BANKS VIEWPOINT ON BITCOIN, THE TAX AND THE LEGAL ASPECT**

When The Central Banks' opinions related to Bitcoin are reviewed, the negative comments are mostly seen. It has been also explained by themselves that they have the similar workings on Bitcoin with these negative comments. Actually, this problem's reason is that they are in a fear of getting lost the initiatives to manage the market with the unlimited monetising power. The central banks which emit the money at tens of times from the value of goods that are produced over the world, especially FED, are definitely uncomfortable from the rise of Bitcoin.

The authorities who have recognized that they will not be able to resist against the period of digital money are aware of the manner that they need to create an alternative for Bitcoin. However, Bitcoin seems not to be a digital money but like an alternative currency for all the currencies.

Some countries have the positive explanations as some of the countries decide that it should be banned.

#### **4.1 The Countries Which Let The Bitcoin Usage**

1. Estonian government has aimed to use the Block-Chain technology for the health, banking and the citizens' participation to the government.
2. The owner with the most cryptocurrency in number and the leader of Bitcoin trade volume over the world is United States of America. Many countries follow the manner that United States of America will take about the legal arrangement of cryptocurrency.
3. Denmark is one of the states which want to abolish the cash usage and to pass to the digital currency. It aims to use Bitcoin and the current digital money in the daily life without giving up Their Central Bank exactly. Danish Central Bank has explained that they will not interfere because Bitcoin is not a currency.
4. Sweden is one of the countries who want to abolish the cash usage like Denmark. The Swedish citizens can use Bitcoin in order that Swedish Central Bank doesn't make a loss from the negative interest implementation of Riksbank. Swedish Financial Monitor Authority has banned Bitcoin as a payment method.
5. Bitcoin has been accepted as a payment method in South Korea who does the honors of the giant firms such as Samsung and LG even if there is not a law which arranges Bitcoin and it has become common every passing day. Bitcoin conferences are organized in South Korea.
6. Arnhem, a city in Holland, is simply a city of Bitcoin. There are more than 100 places which can make the commerce via Bitcoin. Holland's banks have searched the ways of minimizing the expenses as they have developed their own technologies with the method of Block Chain.
7. Finland's Central Tax Council has defined Bitcoin as a financial service and has privileged Bitcoin from the value-added tax.
8. Many countries in Canada make the operation through Bitcoin. As a result of the long discussions, Bitcoin has been arranged within the framework of the act on the money laundering and terror's financing struggle.

9. England does the honors of many Bitcoin and Block-Chain innovative companies. The money proceeding specific to Bitcoin has been made and the value-added tax is implemented for the dealings which are made with Bitcoin.

10. Australia abolished the double taxation that it implemented on Bitcoin but any private arrangement for Bitcoin wasn't made. Australia accepts Bitcoin as a good. (Çarkacıoğlu, 216, 56-58)

11. The arrangement was provided in order that the digital currencies and the encrypted currencies are used in the commerce and dealings, with a code which came into force in Japan on April, 2017. Thus, Bitcoin and another digital currencies have been accepted as an instrument of payment. Furthermore, the commerce of Bitcoin in the markets have become easy because the aforementioned currencies are considered within the scope of valuable assets. (<http://www.haberturk.com/ekonomi/teknoloji/haber/1453992-bitcoin-artik-japonyada-yasal>)

#### **4.2 The Countries Which Don't Let The Bitcoin Usage**

1. Iceland's Central Bank banned Bitcoin operation on March in 2014 as they explained that they are contrary to Iceland's Kambiyo Code.

2. Bangladesh banned Bitcoin in accordance that it is not a legal currency and it can put its users into the financial dangers.

3. Bolivian Central Bank didn't allow Bitcoin's operations in accordance that 'it is not legal to use the money which isn't printed or controlled by a government or the authorities'.

4. Ecuador banned Bitcoin in order to prevent the competition as it works for printing its own digital money.

5. Thailand's Central Bank declared that Bitcoin Usage is not legal as there is not a legal infrastructure for Bitcoin on July, 2013. (Çarkacıoğlu, 216, 58)

Dimon, who is JP Morgan Chase CEO and who take an aim at Bitcoin as a digital currency explained harshly that any of JP Morgan's workers will be dismissed if he/she makes an operation with Bitcoin. He went on as stating that Bitcoin will end one day, during his speech for the investors in New York: *'If an employee of JP Morgan makes an operation with Bitcoin, I dismiss him/her immediately. Due to two reasons: first of them is that it is against our rules and the second one is that this action is a stupidity. So it is dangerous in two ways.'* Dimon who said that Bitcoin is only a fraud type reminded "tulip mania" which is known as the history's first economical balloon. "The Tulip Mania" which is mentioned as the history's first economic balloon is used by the economy community for the period that the tulip bulb prices rose too

much suddenly as a speculative and collapsed in Holland in 1630's.  
(<https://tr.sputniknews.com/ekonomi/201709131030117738-dimon-jp-morgan-kovarim-bitcoin>)

Janet Yellen who is the former Head of FED in American Central Bank said '*Bitcoin is not a stable saving instrument but it is very speculative asset*' while he evaluated about Bitcoin which have broken the records in the recent days. As Bitcoin has got a small place in the payment system, he emphasized that its risks related to the financial stability are limited. Yellen who indicated that FED's role related to audit Bitcoin is very little said '*FED doesn't use the digital currency significantly now but it searches its possible benefits.*'  
([https://www.ntv.com.tr/ekonomi/fedden-bitcoin-aciklamasi, onZ5ss Bk\\_UWUEH57 AikTxQ](https://www.ntv.com.tr/ekonomi/fedden-bitcoin-aciklamasi, onZ5ss Bk_UWUEH57 AikTxQ))

Murat Uysal who is the Vice President of Turkish Republic Central Bank declared that Bitcoin is not a currency because it has not got the functions such as the medium of money exchange, medium of value and protection and the basket money. He stated that Block-chain technology is a different field, the developments of this field can be used in the future but it has got a great risk and it is a speculative product because there are not any authorities behind Bitcoin (state, central bank etc.). Moreover, the current deficit which occurs in the countries which have to import the energy as in Turkey will increase and grow in the case that the investments are directed to Bitcoin. It seems that this important problem that Uysal indicated it escaped the authorities' notice. Furthermore, it is necessary not to confuse the digital money with the cryptocurrency. The digital money is the money which has a corresponding, has an authority behind it, and which is sufficient to make an operation in the faster way. Cryptocurrency has not got any of these features.

While Bitcoin recreated its historical peak with 7 thousands and 404 dollars on 02.11.2017, Murat Cetinkaya who is the Head of Turkish Republic Central Bank (TRCB) said that the bitcoins can create a positive impact on the financial stability. Cetinkaya stated that the digital currencies will support the financial system in the case that they are designed well, as designating that he follows the developments in the digital currencies of TRCB. Cetinkaya gone on his news release as the following:

“Bitcoin which is known as one of the bitcoin types that is not exported by any formal or private institutions and that the security is not given for its corresponding is not considered as an electronic money within the scope of Code by means of its current structure and proceeding so its observance and audit are not considered as possible within the framework of the aforementioned Code.

Furthermore, it creates a suitable setting in order that the aforementioned bitcoins are used in the illegal activities because the parties' identity is not known in the

operations which are made with Bitcoin and the similar bitcoins. Moreover, Bitcoin is open to the risks arising from the operational errors and the malevolent sellers' abuse as the operations which are made can not be turned back with the risks that the going price is an excessive unsteady, the digital wallets can be stolen, they can be gotten lost or they can be used as illegal without their owners' information. It is considered as beneficial to declare the above-stated terms and to remind the possible risks in Bitcoin and similar bitcoins to the public opinion within this framework in order that there are not any unjust treatments." (25/11/2013[https://www.bddk.org.tr/WebSitesi/turkce/Duyurular/Basin\\_Aciklamalari/12574bitcoin\\_hk\\_basin\\_aciklamasi.pdf](https://www.bddk.org.tr/WebSitesi/turkce/Duyurular/Basin_Aciklamalari/12574bitcoin_hk_basin_aciklamasi.pdf))

Vitor Constancio who is the Vice President of European Central Bank explained his opinions about the risks that those who invest on Bitcoin take them, with the general economical evaluations on his statement. Vitor Constancio said that the changing in Bitcoin's prices make it a speculative one and he gone on as the following:

"The investors take risks as having with such high prices. The world's press has started to focus much more on Bitcoin as it has increased in the recent weeks. As it is a cryptocurrency, it has a great impact on this situation. As Bitcoin's price rose from nearly 8.000 dollars to 10.000 dollars and then, it decreased fastly to the below of 10.000-dollar value, the situation increased the rumors about 'bitcoin balloon' in the financing world." (<https://webrazzi.com/2017/12/01/avrupa-merkez-bankasi-baskan-yardimcisi-bitcoin-almak-buyuk-risk/>)

### **4.3 The Accounting, Tax and Legal Aspect**

It is seen that there are different opinions about Bitcoin which has not taken its place in Turkish Tax legislation yet. It is seen that it is accepted as a commodity on some of paradigms and it is defined as a foreign currency on some paradigms.

When its general usage is considered, it is used as an instrument of payment or an investment instrument. It will be a correct paradigm that the profit and loss which occur are recorded in the accounting as the foreign exchange profit and foreign exchange loss as it is accepted as a foreign currency.

As there has not been any arrangements in our tax code, it is not possible to make the collection of tax. One of the most important reasons that Bitcoin has started to be used in such a common way is that the tax is not taken. On condition that it is included in the tax system, its target to be an alternative in the system as its occurrence goal will disappear.

Bitcoin has not been defined in the law system. If there is an illegal expense which is made in the foreign countries and in the domestic, the penalty which will be made will be due to the operation but not due to the usage of Bitcoin. The commerce of drugs, the commerce of weapons or the support for the terror are the negative experiences which are seen.

As it is new as a value unit, it will be correct that the legal arrangements related to the types of bitcoins are made when it is foreseen that Bitcoin usage will go on or increase as parallel with the other world countries even if any legal arrangements related to Bitcoin have not been made in Turkey yet. (Armağan- Bozkurt, 2015, 212).

It became possible to have a dealing with Bitcoin in the period that Bitcoin appeared firstly, as your identity information was hidden through the web page with the name of Silk Road which was opened to be used. The person that FBI started to follow him was arrested with the claim that he bought the drugs and he was in a murder, and they distrained his Bitcoins. Thus, FBI became one of the biggest members ironically in the community.

## **CONCLUSION**

When the searches and comments on Bitcoin are considered, it is seen that there is not exactly resolution. Its most important reason is that the issue has not been understood exactly even by the central authorities yet and so they have not developed a strategy. It is seen that the countries who banned Bitcoin explained that they started to work on Bitcoin after a while. So it will be good to evaluate the positive and negative aspects related to Bitcoin.

The Advantages:

1. Bitcoin and similar cryptocurrencies have affected closely on the financial markets; it has provided superiority with the advantages such as its operation speed, the opportunity to make an operation in each hour of a day, the free or very low remission commission. It has exposed the companies having their operation with the standart currencies to the obligation to make the revision. (Gültekin, 2017, 110)
2. The increase in the real money supplies that The Central Banks release as free of charge causes the inflation. Bitcoin is a limited system, its maximum production capacity is 21 millions. Thus, the inflation risk of Bitcoin is not a subject. The investors and those who use it as a changing instrument will not be affected from the inflation.
3. It is possible to do the intended operation in the whole day without requiring any intermediary with the peer-to-peer system.
4. As many countries have not included it into the system today, its tax advantage has gone on.

The Disadvantages:

1. When Bitcoin's financial assets features are reviewed "as the bitcoin unit, the situations that it is the assets with an excessive risk, its pricing mechanism is based on the different information factors with the support/demand conditions, its returns are speculative, its changefulness varies in time, the arbitrage among the markets is observed, the markets that it has its operation in them have insufficiency on audit/arrangement and the prices are not stable occur." (Hepkorucu- Genç, 2017, 55-56)
2. Especially, as the rapid transfer which is independent from the authority, without recourse, unlimited and nearly at no cost attracts the attention of some users, the width of daily price ranges doesn't escape the investors' notice in the speculative purpose. It is seen as an important threat that it facilitates the usage related to the illegal operations (Sönmez, 2014, 13).
3. As Bitcoin was produced as a system that it has not got a central authority, it is not very close to the classical investor model. The man want to see the money as an abstract one, to keep it in his/her hand, to save it, to know that the money is safe as saving it by nature. Bitcoins or the other altcoins can not provide it.
4. Bitcoin that its workings were previously started was declared by Satoshi Nakamoto on a setting that the central authority's trust was abused as a result of 2008 economical crisis. However, it was laterly understood that the name of Satoshi Nakamoto is a nickname and as a result of insistent searches, Craig Wright said that Satoshi Nakamoto is himself. But the situation could not convince the people, the suspicion that Satoshi Nakamoto is another person or on another power has gone on.
5. 5% of all the Bitcoins are available in the hand of Bitcoin producer. This situation creates the following disadvantage; if he supplies all of Bitcoins or a great part of them to the system, it can cause the significant decreases in Bitcoin prices.
6. If there is a transfer to an incorrect address in the operations which are made freely in 24 hours thanks to peer-to-peer model, it is seen as another disadvantage of this system that the transfer can not be returned definitely.
7. There is nothing to do on condition that the password is forgotten or the computers that the Bitcoins are kept in them are not reached as the cold wallets are preferred or Bitcoins are not found on the paper setting. For example, it is said that 3.8 million of 16.4-million Bitcoin got lost during the loop in the middle of 2017 so that this is nearly 30 billions dollars. (<http://www.webtekno.com/ortalama-30-milyar-dolar-degerinde-bitcoin-cope-gitti-h37058.html>)



It is certain that the block-chain usage that Bitcoin or other similar altcoin technology is used will be common in the future. It will be certain whether the changeover for this system will be via the central authorities or the alternative system which is against Bitcoin or similar central authorities, and who will gain the war of power and money in the following days.

## **REFERENCES**

### **Book and Articles:**

Ateş Aslantaş, Burcu. (2016). The Cryptocurrency, Bitcoin and Accounting. Cankiri Karatekin University, The Journal of Social Science Institute.

Atik, Murat- Köse, Yaşar- Yılmaz, Bülent- Sağlam, Fatih. (2015). Cryptocurrency: Its Impacts on Bitcoin and Exchange Rates. Bartın University, The Journal of FEAS.

Balay, Refik. (2004). Globalization, Information Society and Education. Ankara University, The Journal of Faculty of Educational Sciences.

Başçı, Erdem- Kara, Hakan. (2011). Financial Stability and Monetary Policy. Turkish Republic Central Bank's Official Statement No:11.

Bilir, Hakan- Çay, Şerif. (2016). Electronic Money and The Relationship between The Financial Markets. Nigde University, The Journal of Faculty of Economics and Administrative Sciences.

Çarkacıoğlu, Abdurrahman. (2016). Cryptocurrency Bitcoin. Stock Exchange Commission.

Gültekin, Yaşar. (2017). Cryptocurrencies As An Alternative Payment Instrument in Tourism Industry: Bitcoin. The Journal of Current Tourism Searches.

Hepkorucu, Atilla- Genç, Sevdanur. (2017). The Review on Bitcoin As A Financial Assets and A Practice on The Unit Root Structure. Osmaniye Korkut Ata University, The Journal of Faculty of Economics and Administrative Sciences.

Koçoğlu, Şahnaz- Çevik, Yasin Erdem- Tanrıöven, Cihan. (2016). The Activity of Bitcoin Markets, The Liquidity and Changefulness. The Journal of Management Searches.

Sönmez, Asuman. (2014). Bitcoin as a bitcoin. The Turkish Online Journal of Design, Art and Communication.

Vigna, Paul-Casey, Michael J. (2017). Bitcoin and Digital Money's Challenge Against The Global Economical System, The Cryptocurrency Age. Translator: Ali Atav. Ankara: Buzdağı Publisher.

Yüksel Bozkurt, Armağan Ebru. (2015). A Legal View on Electronic Money, Bitcoin, Bitcoin and Linden Dollar. The Journal of Istanbul University Law School.

Zengin, Burcu- Güngördü, Aybegüm. (2013). A Review on The Possible Impacts of Electronic Payment Systems. Gazi University, The Journal of Faculty of Economics and Administrative Sciences.

**Internet Sources:**

<https://tr.sputniknews.com/ekonomi/201605021022488232-bitcoin-avustralya-craig-wright>, Access date 05.10.2017.

Karaarslan Enis – Akbaş Muhammet Fatih. Blok Zinciri Tabanlı Siber Güvenlik Sistemleri. [https://www.researchgate.net/publication/320083329\\_Blok\\_Zinciri\\_Tabanli\\_Siber\\_Guvenlik\\_Sistemleri\\_Blockchain\\_Based\\_Cyber\\_Security\\_Systems](https://www.researchgate.net/publication/320083329_Blok_Zinciri_Tabanli_Siber_Guvenlik_Sistemleri_Blockchain_Based_Cyber_Security_Systems), Access date 03.01.2018.

<http://www.meko9.com/kripto-para-cuzdan-cesitleri-ve-ozellikleri/> Access date 12.12.2017.

<http://coin-turk.com>, Access date 03.01.2018.

<https://tr.sputniknews.com/ekonomi/201709131030117738-dimon-jp-morgan-kovarim-bitcoin>, Access date 13.09.2017.

<https://www.ntv.com.tr/ekonomi/fedden-bitcoin-aciklamasi>, onZ5ss Bk\_UWUEH57 AikTxQ, Access date 04.01.2018.

25/11/2013 [https://www.bddk.org.tr/WebSitesi/turkce/Duyurular/Basin\\_Aciklamalari/12574bitcoin\\_hk\\_basin\\_aciklamasi.pdf](https://www.bddk.org.tr/WebSitesi/turkce/Duyurular/Basin_Aciklamalari/12574bitcoin_hk_basin_aciklamasi.pdf), Access date 12.12.2017.

<https://webrazzi.com/2017/12/01/avrupa-merkez-bankasi-baskan-yardimcisi-bitcoin-almak-buyuk-risk/>, Access date 05.01.2018.

<http://www.haberturk.com/ekonomi/teknoloji/haber/1453992-bitcoin-artik-japonyada-yasal>, Access date 07.12.2017.

[http://www.elektrikport.com/teknik-kutuphane/peer-to-peer-\(p2p\)-aglar-nedir-ve-nasil-calisir/15406#ad-image-1](http://www.elektrikport.com/teknik-kutuphane/peer-to-peer-(p2p)-aglar-nedir-ve-nasil-calisir/15406#ad-image-1), Access date 30.01.2018.

<http://www.webtekno.com/ortalama-30-milyar-dolar-degerinde-bitcoin-cope-gitti-h37058.html>, Access date 04.02.018.

<https://uzmancoin.com/en-iyi-bitcoin-borsalari/>, Access date 04.02.2018.

<http://coin-turk.com/bitcoin-atmleri-hizla-yayginlasiyor>, Access date 04.02.2018.

<https://kriptoparahaber.com/turkiyedeki-bitcoin-ve-kripto-para-borsalari.html>, Access date 04.02.2018.

**Oral Sources:**

The conversation which was made with Murat Uysal, who is the Vice Chairman of Turkish Republic Central Bank, on 30.01.2018.